



ROMETAL













Manual de Montagem
Manual de Instalación
Installation Manual

SISTEMA DESLIZANTE PARA ARMÁRIOS
SISTEMA CORREDIZO PARA GABINETES
SLIDING SYSTEM FOR CABINETS

SUPREMO – PARA PORTAS DE ALUMÍNIO

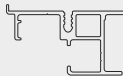

Componentes do sistema
Componentes del sistema
Components of the system

Itens na caixa/ <i>Items en la caja/</i> Box content		TOP
	Carro superior esquerdo/ <i>Carro superior izquierdo/</i> Top left trolley	1
	Carro superior direito/ <i>Carro superior derecho/</i> Top right trolley	1
	Dobradiça superior esq./ <i>Bisagra superior izquierda/</i> Top left hinge	1
	Dobradiça superior dir./ <i>Bisagra superior derecha/</i> Top right hinge	1
	Dobradiças centrais/ <i>Bisagras centrales/</i> Center hinges	4
	Carro inferior esquerdo/ <i>Carro inferior izquierdo/</i> Bottom left trolley	1
	Carro inferior direito/ <i>Carro inferior derecho/</i> Bottom right trolley	1
	Dobradiça inferior esq./ <i>Bisagra inferior izquierda/</i> Bottom left hinge	1
	Dobradiça inferior dir./ <i>Bisagra inferior derecha/</i> Bottom right hinge	1
	Gabarito/ <i>Plantilla/</i> Gauge	1
	Chave Allen/ <i>Llave Allen/</i> Hex key	1
	Chave 8 mm/ <i>Llave 8 mm/</i> 8 mm wrench	1
	Amortecedor/ <i>Amortiguador/</i> Damper	2
	Trilho superior RM-269/ <i>Riel superior RM-269/</i> RM-269 top track	-
	Trilho inferior RM-270/ <i>Riel inferior RM-270/</i> RM-270 bottom track	-



Espessura de
Espesor de
Thicknesses espesor to
15 a 25 mm



Para portas de até **35 Kg**
(17,5 Kg por folha)
Para puertas hasta **35 Kg**
(17,5 Kg por hoja)
For doors up to **35 Kg**
(17,5 Kg per leaf)



Recomenda-se o uso do
desempenador **DP-200**
Se recomienda el uso
del enderezador **DP-200**
The use of the **DP-200**
straightener is recommended



Largura mínima da folha
Ancho mínimo de la hoja
Minimum width of the leaf
300 mm



Largura máxima da folha
Ancho máximo de la hoja
Maximum width of the leaf
600 mm



Portas de madeira e alumínio
Puertas de madera y aluminio
Wooden and aluminum doors
OBS: Para portas de alumínio consulte
o manual específico.
Para puertas de aluminio consultar
el manual específico.
For aluminum doors consult
the specific manual.

Nivelção do móvel Nivelación del mueble Level the furniture

O móvel precisa estar nivelado e as portas não devem estar empenadas.
El mueble necesita estar nivelado y las puertas no deben estar pandeadas.
Make sure the furniture is level and the doors are not warped.

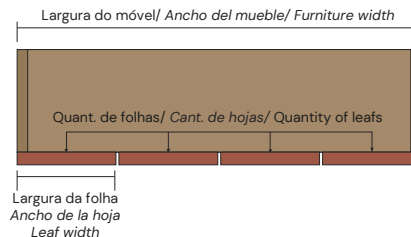
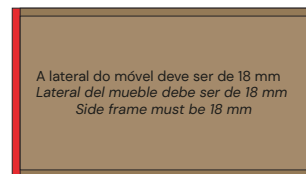
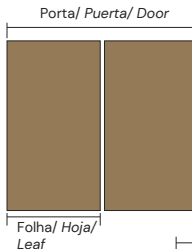
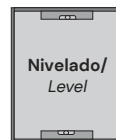
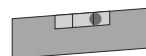
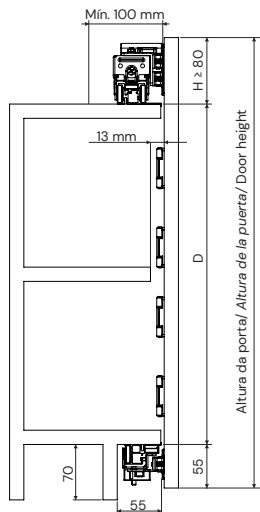

Cálculo para largura de portas Cálculo para ancho de puertas Door width calculation

Largura da porta = (largura do móvel / quantidade de folhas) - 2
Ancho de puerta = (ancho del mueble / cantidad de hojas) - 2
Door width = (Furniture width / Quantity of leaves) - 2

Exemplo para móvel de 4 folhas com 2000 mm de largura
Ejemplo para mueble de 4 hojas con 2000 mm de ancho
Example for furniture with 4 leaves and 2000 mm wide
(2000 / 4) - 2 = 498 mm

1 Construção da porta. | Construcción de la puerta. | Door construction.

1.1 - Corte o perfil 45° | 1.1 - Cortar el perfil 45° | 1.1 - Cut the profile 45°

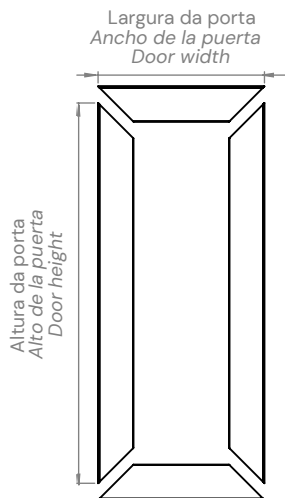

Exemplo de puxador: RM-414 e RM-424.
Ejemplo de tirador: RM-414 y RM-424.
Example of handle: RM-414 and RM-424.

Perfil compatível: RM-323.
Perfil compatible: RM-323.
Compatible profile: RM-323.

1.2 - Furar e escarear os perfis | 1.2 Taladrar y avellanar los perfiles | 1.2 Drilling and countersinking the profiles

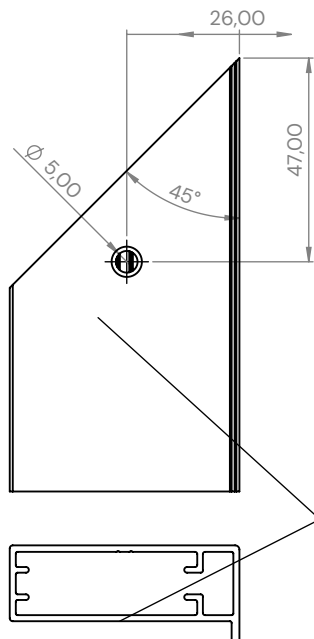

Face em contato com o vidro.
Cara en contacto con el vidrio.
Face in contact with the glass.

1.3 - Aplique as esquadretas |

1.3 - Aplicar las escuadras |

1.3 - Apply the squares

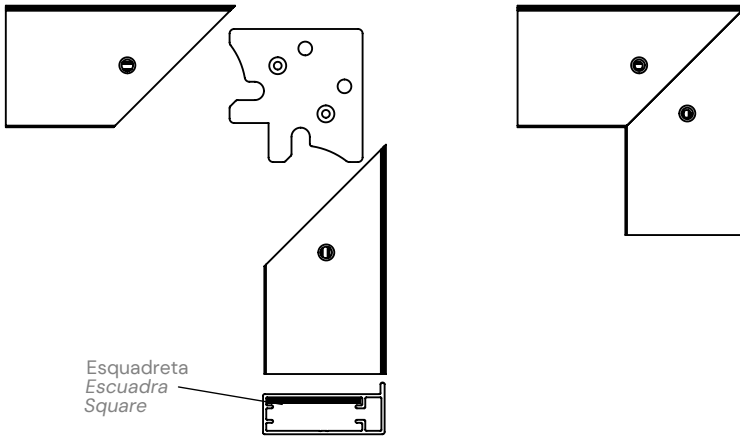

1.4 - Usinar a porta |

1.4 - Mecanizado de la puerta |

1.4 - Machining the door

Para H igual a 80, deixar o gabarito rente a porta.

Para H igual 80, dejar la plantilla alineada a la puerta.

For H equal to 80, leave the template close to the door.

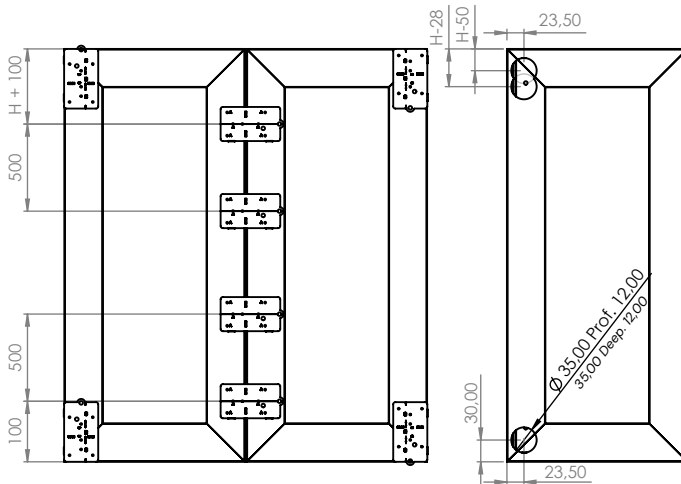

Faça as furações para as dobradiças laterais utilizando as marcações B no gabarito.

Haga las perforaciones para las bisagras laterales utilizando las marcaciones B en la plantilla.

Drill the holes for the side hinges using the pattern B markings of the template.

Faça as furações para as dobradiças centrais utilizando as marcações A no gabarito.

Haga las perforaciones para las bisagras centrales utilizando las marcaciones A en la plantilla.

Drill the holes for the central hinges using the pattern A markings of the template.

· Após usinado aplique o vidro.

Después del mecanizado aplique el vidrio.

After machining, apply the glass.

2

Soltar os carros das dobradiças. | Liberar los carros de las bisagras. | Loosen the carriers from the hinges.

Para os carros superiores, solte as porcas e desencaixe as partes.
 Para los carros superiores, desatornille las tuercas y desconecta las partes.
 For the top trolley, loosen the nuts and separate the parts.

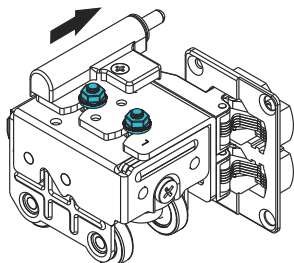

Para os carros inferiores, aperte o botão inferior e desencaixe as partes.
 Para los carros inferiores, apretar el botón inferior y desacoplar las partes.
 For top trolley, press the bottom button and separate the parts.

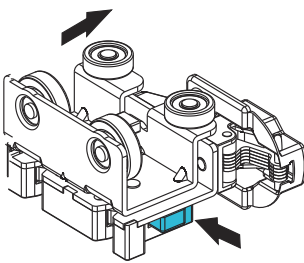

3

Instale as dobradiças centrais e laterais, tomando cuidado para não inverter as dobradiças esquerda e direita. | Instale las bisagras centrales y laterales, con atención para no cambiar las bisagras izquierdas y derechas. | Install the center and side hinges being careful not to mix up the left and right hinges.

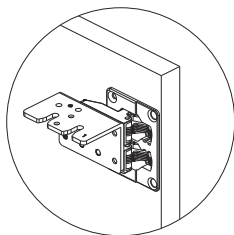

Dobradiça superior
 Bisagra superior
 Top hinge

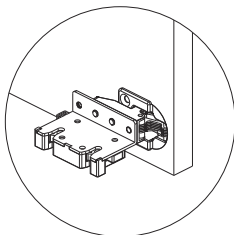

Dobradiça inferior
 Bisagra inferior
 Bottom hinge

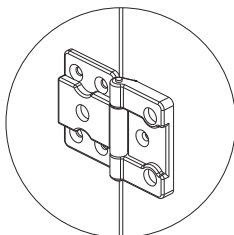

Dobradiça central
 Bisagra central
 Center hinge

Todas as dobradiças centrais devem estar na mesma direção.

Todas las bisagras centrales deben estar en el mismo sentido.

All the center hinges must be oriented in the same direction.

Parafusos indicados: 3,9 x 9,5 CC auto-atarraxante.
 Tornillos recomendados: 3,9 x 9,5 CC autorroscantes.
 Recommended screws: 3.9 x 9.5 CC self-tapping.

4

Posicione os carros superiores e amortecedores no trilho superior. | Posicione los carros superiores y amortiguadores en el riel superior. | Position the top trolley and the dampers on the top track.

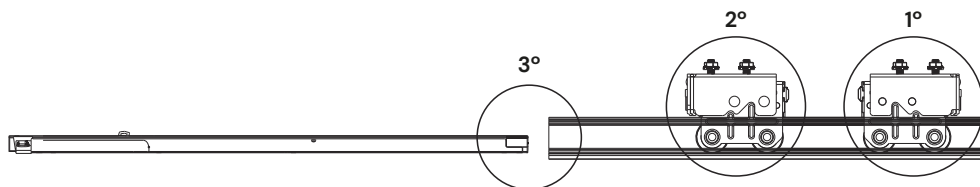

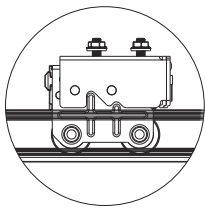

1°

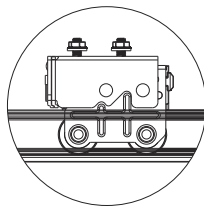

2°

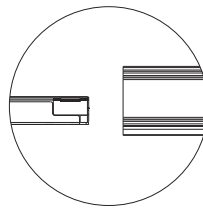

3°

Vista lateral do posicionamento dos carros:

Vista lateral del posicionamiento de los carros:

Side view of the position of the trolley:

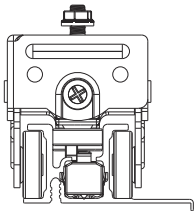

Sentido de instalação do amortecedor no trilho superior:

Sentido de instalación del amortiguador en el riel superior:

Installation direction of the damper on the top track:

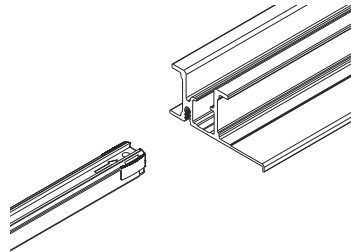

O amortecedor deve estar acionado.

El amortiguador debe estar accionado.

The damper must be activated.

5

Posicione os carros inferiores e amortecedores no trilho inferior. | *Posicione los carros inferiores y amortiguadores en el riel inferior.* | *Position the bottom trolley and the dampers on the bottom track.*

3°

2°

1°

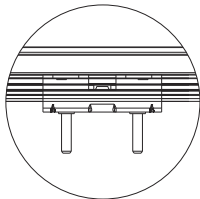
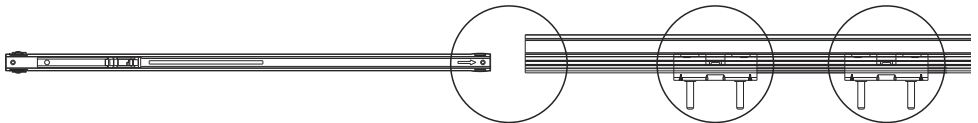

1°

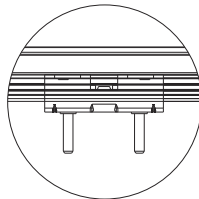

2°

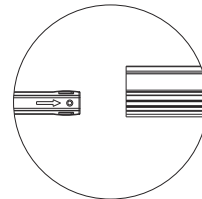

3°

Vista lateral do posicionamento dos carros:
Vista lateral del posicionamiento de los carros:
Side view of the position of the trolley:

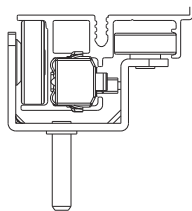

Sentido de instalação do amortecedor no trilho inferior:
Sentido de instalación del amortiguador en el riel inferior:
Installation direction of the damper on the top track:

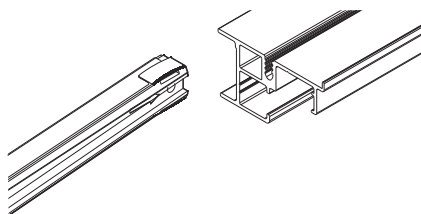

O amortecedor deve estar acionado.
El amortiguador debe estar accionado.
The damper must be activated.

6

Instalação dos trilhos. | *Instalación de los rieles.* | *Track installation.*

Fixação externa *Fijación externa* *External fixing*

Realizar os furos no trilho seguindo as medidas abaixo.
Hacer las perforaciones en el riel como las medidas indicadas.
Drill the holes in the specific lines of the track by following the measurements below:

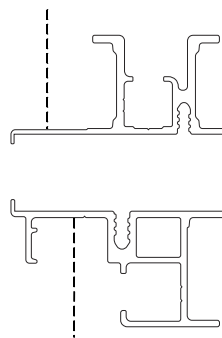
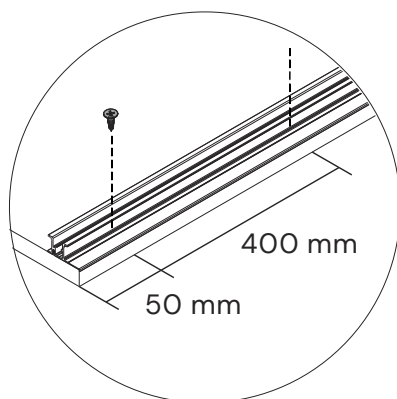
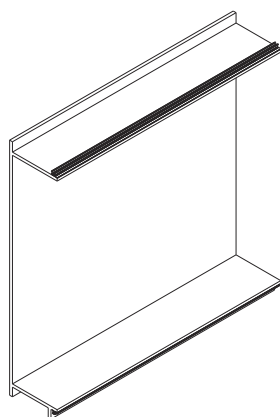

Fixação interna
Fijación interna
Internal fixing

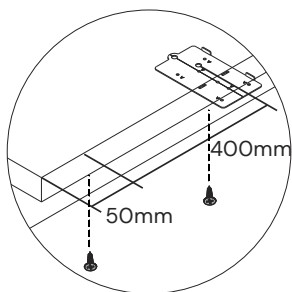
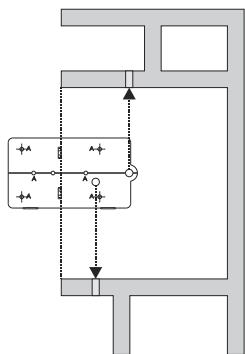

Utilizar o gabarito
Utilizar la plantilla
Use the gauge

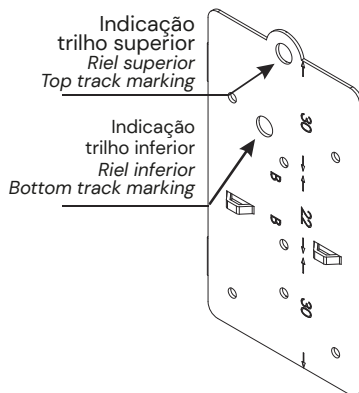

7

Instale as portas. | *Instale las puertas. | Fit the doors.*

Encaixe os carros superiores nas dobradiças superiores e aperte as porcas:
Encaje los carros superiores en las bisagras superiores y aprete las tuercas:
Attach the top trolley to the top hinges and tighten the nuts:

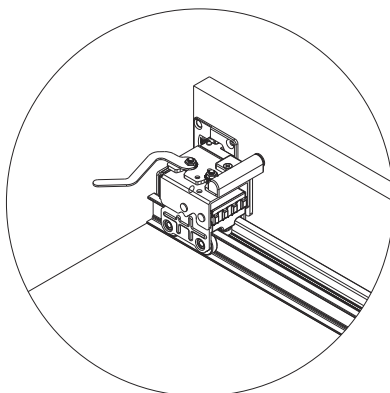
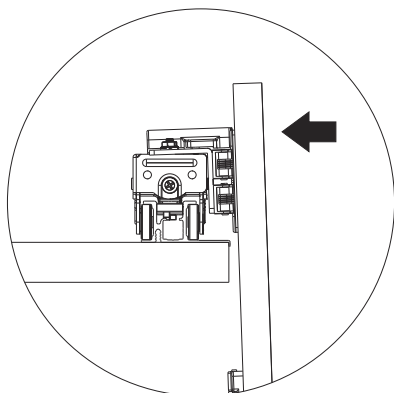

Encaixe os carros inferiores nas dobradiças inferiores através do sistema click:
Encaje los carros inferiores en las bisagras inferiores a través del sistema click:
Attach the bottom trolley to the bottom hinges using the click system:

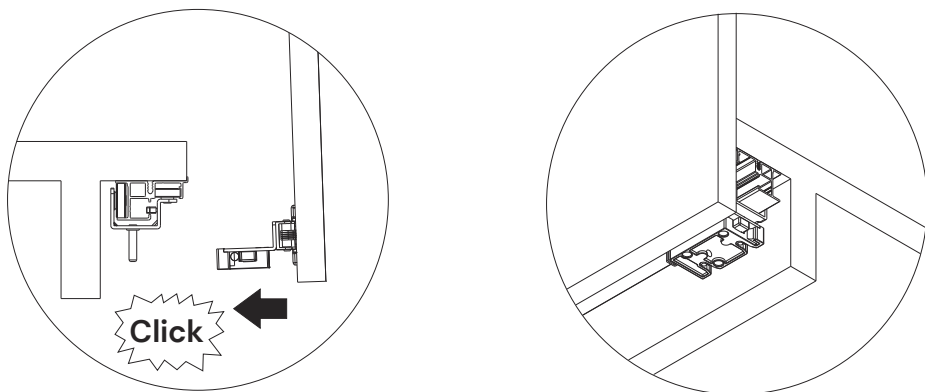

8 Regule a altura das portas. | *Regule la altura de las puertas.* |
Adjust the height of the doors.

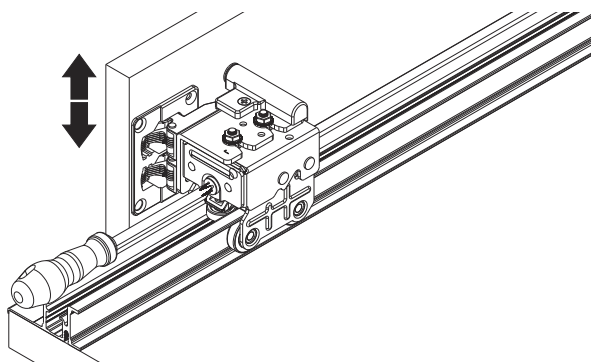

9 Regule a posição do amortecedor. | Regule la posición del amortiguador. | Adjust the position of the damper.

Caso seja necessário, faça o tamponamento.

Si necesario, haga una tapa.

If necessary, use a cover cap.

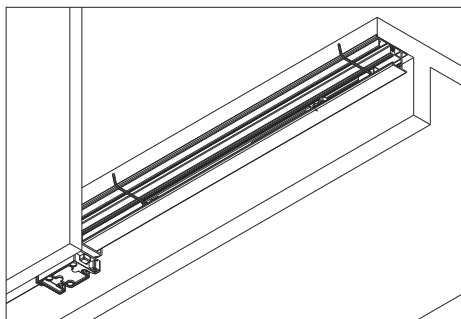
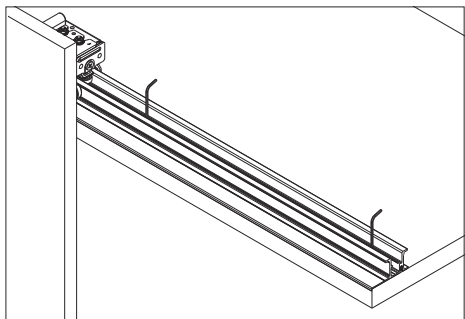

10 Desinstalação das portas. | Retirada de las puertas. | Removing the doors.

1º Solte o sistema inferior pelo botão de desencaixe.

1º Liberar el sistema inferior a través del botón.

1st: Release the bottom system by pressing the release button.

2º Solte o sistema superior pelas porcas de fixação.

2º Liberar el sistema superior a través de las tuercas.

2nd: Unscrew the nuts to release the top system.

3º Erga um pouco a porta para desencaixá-la do sistema superior.

3º Levantar la puerta para desacoplarla del sistema.

3rd: Lift the door a little to remove it from the top system.

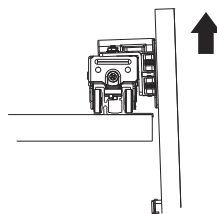
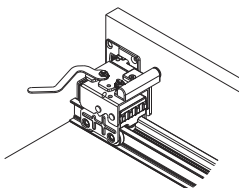
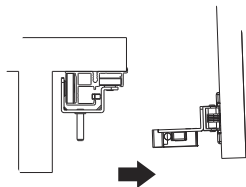



Rev.: 11
Cód: 16908