



Manual de Montagem
Manual de Instalación

SISTEMA DE AMORTECIMENTO
SISTEMA DE AMORTIGUACIÓN

AGILITY PLUS



Verifique se o amortecedor é adequado ao peso da porta
Compruebe si el amortiguador está adecuado al peso de la puerta

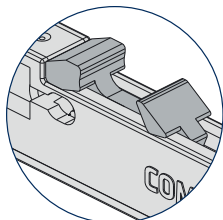

Gatilho cinza
Médio (15 a 40 Kg)

Gatillo gris
Mediano (15 hasta 40 Kg)

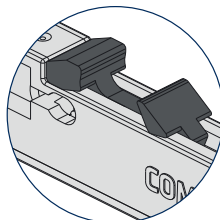

Gatilho preto
Pesado (40 a 60 Kg)

Gatillo negro
Pesado (40 hasta 60 Kg)

Portas | Puertas

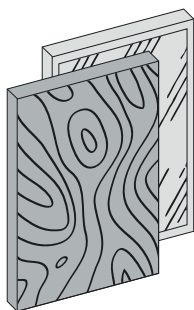

Produto brasileiro
Hecho en Brasil

Peso até 60 kg / *Peso hasta 60 kg*

Desconto de porta / *Descuento de la puerta:*

Vão interno do móvel – 53mm / *Vano interno del mueble – 53mm*

Largura mínima: 500 mm / *Ancho mínimo: 500 mm*

Portas de 500 a 700mm de largura devem ter no mínimo 20 Kg e relação de altura x largura de 4:1, ou seja, uma porta de 500 mm de largura pode ter, no máximo, 2000 mm de altura.

Puertas de 500 hasta 700mm de ancho deben tener al mínimo 20 Kg y altura x ancho de 4:1 o sea, una puerta de 500 mm de ancho puede tener máximo 2000 mm de altura.

Portas de madeira e alumínio / *Puertas de madera y aluminio*

Itens na caixa/ Items en la caja	Top /3 p	Top	Standard	Basic	
	Amortecedor Amortiguador	6	2	1	-
	Guia superior Guía superior	4	2	2	2
	Guia sem acionador Guía sin accionador	2	-	-	-
	Freio Freno	-	-	1	2

O Agility Plus pode ser utilizado com os sistemas:
RO-47, RO-62 e RO-65.

El Agility Plus puede ser utilizado con los sistemas:
RO-47, RO-62 y RO-65.

Trilhos exclusivos Rometal/ Rieles exclusivos Rometal

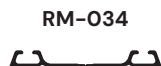
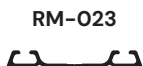
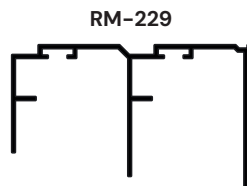
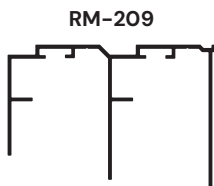
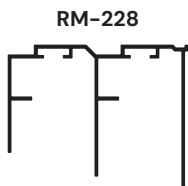

Verificar se o móvel está nivelado e as portas não estão empenadas.
Compruebe si el mueble esta nivelado y si las puertas no estan pandeadas.

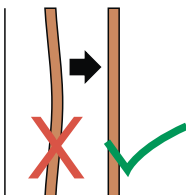
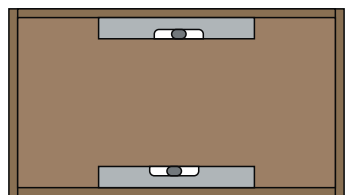

Utilizar desempenadores nas portas.

Sistemas embutidos
Sistemas empotrados

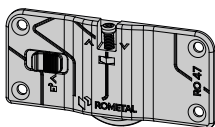

RO-47

Portas/ puertas
15 - 18 mm

Portas/ puertas
20 - 22 mm

Portas/ puertas
25 mm

RM-228
(Superior)

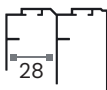

RM-022
(Inferior)



RM-209
(Superior)

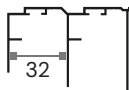

RM-023
(Inferior)



RM-229
(Superior)

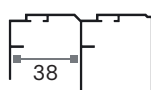

RM-034
(Inferior)



Espaçamentos entre portas RO-47 (medidas aproximadas)
Espaciamientos entre las puertas RO-47 (medidas aproximadas)

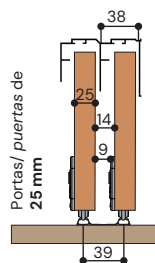
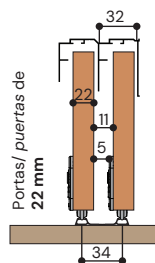
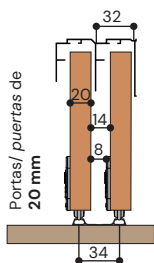
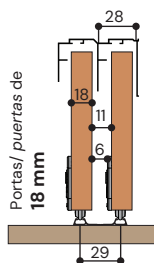
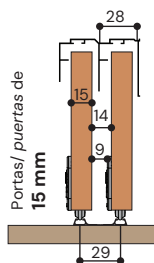

Furações para instalação do RO-47
Perforaciones para instalación del RO-47

MDF

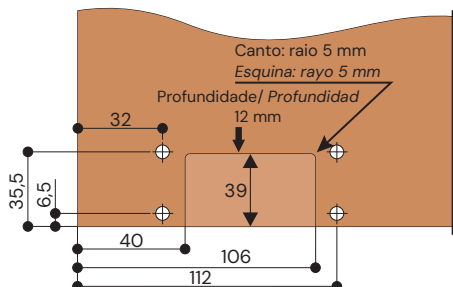

Alumínio/ Aluminio

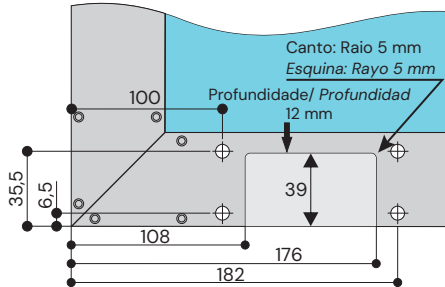

Fixar o carro deslizador no local onde foram feitas as furações.
 Fijar el sistema corredizo en el local que fueran hechas las perforaciones.

Sistemas sobrepostos

Sistemas sobrepuestos

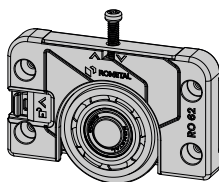

RO-62

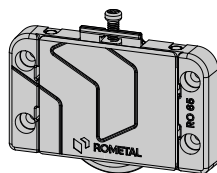

RO-65

Portas/ puertas
15 mm

Portas/ puertas
18 - 20 mm

Portas/ puertas
22 - 25 mm

RM-228
(Superior)

RM-022
(Inferior)

RM-209
(Superior)

RM-023
(Inferior)

RM-229
(Superior)

RM-034
(Inferior)

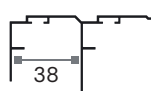
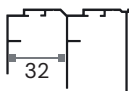
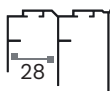

Espaçamentos entre portas RO-62 e RO-65 (medidas aproximadas)

Espacimientos entre las puertas RO-62 y RO-65 (medidas aproximadas)

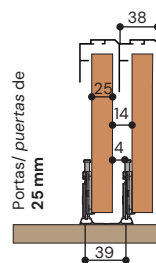
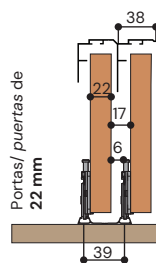
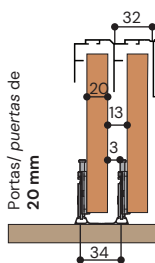
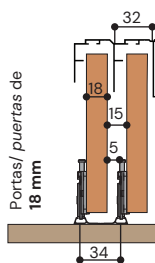
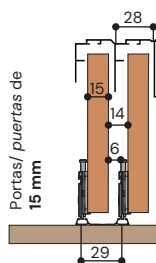

Furações para instalação do RO-62 e RO-65

Perforaciones para instalación del RO-62 y RO-65

MDF

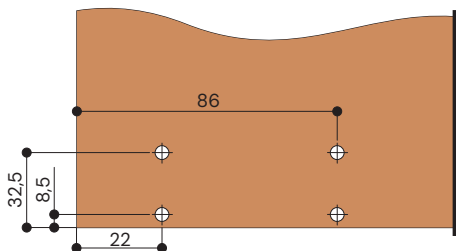

Alumínio/ Aluminio

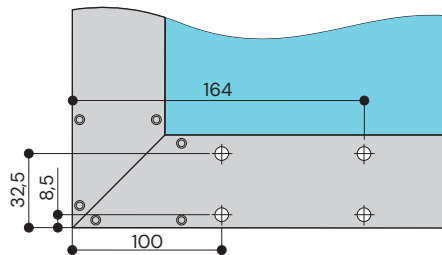

Fixar o carro deslizador no local onde foram feitas as furações.

Fijar el sistema corredizo en el local que fueran hechas las perforaciones.

1 **Faça as furações nos trilhos superior e inferior.** | *Hacer las perforaciones en los rieles superior e inferior.*

Furações a cada 400 mm para evitar empenamento.

Perforaciones a cada 400 mm para que no haya pandeamiento.

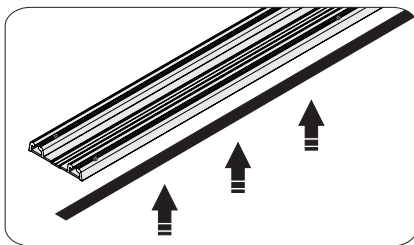
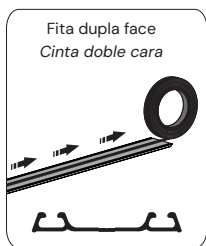
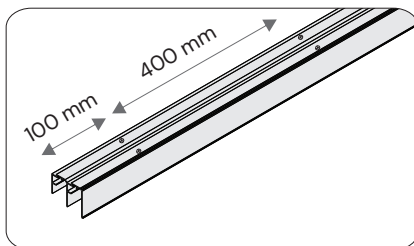
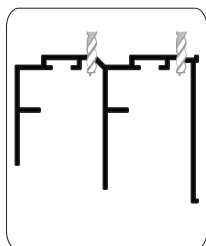

2 **Encaixe as chapas para fixar os freios e amortecedores.** | *Encaje las chapas para fijar los frenos y amortiguadores.*

Freio
Freno

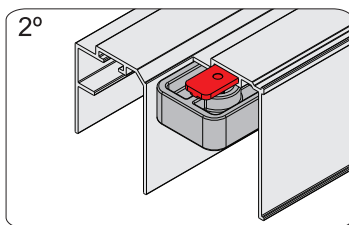
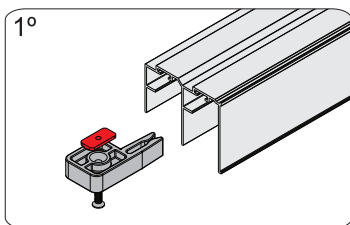

Amortecedor
Amortiguador

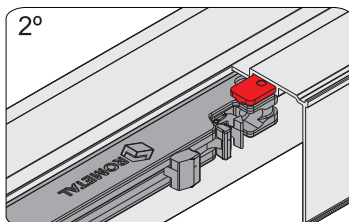
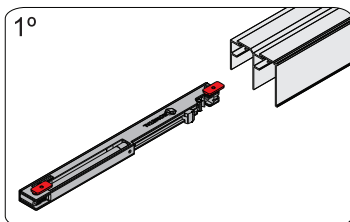

Obs.: o amortecedor deve estar acionado.

Obs.: el amortiguador debe estar accionado.

3 Fixar os trilhos superior e inferior. | Fijar los rieles superior y inferior.

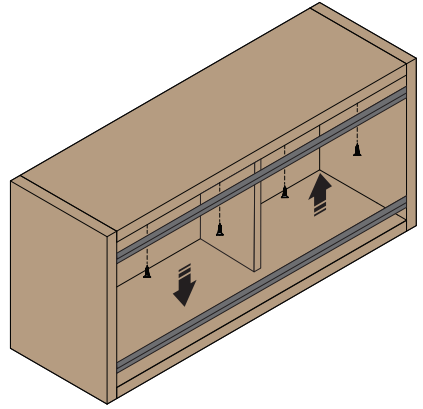
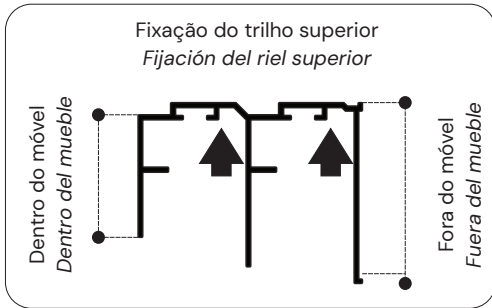

4 Verificar o espaçamento do trilho e ajustar o guia corretamente. | Comprobar el espacio del riel y ajustar el guía correctamente.

RM-228

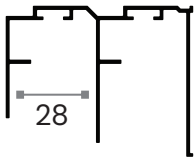

RM-209

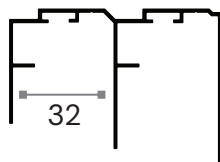

RM-229

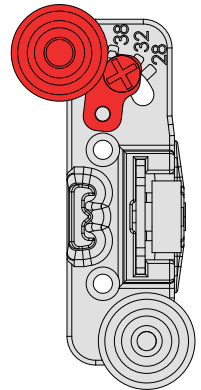
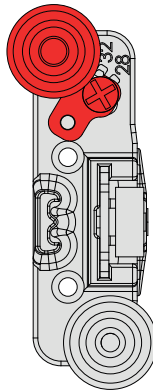
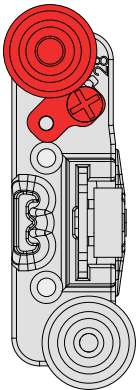
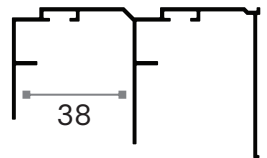

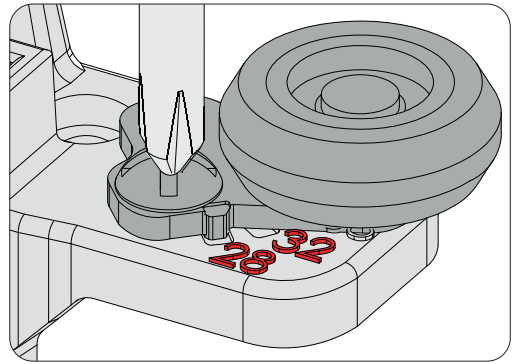
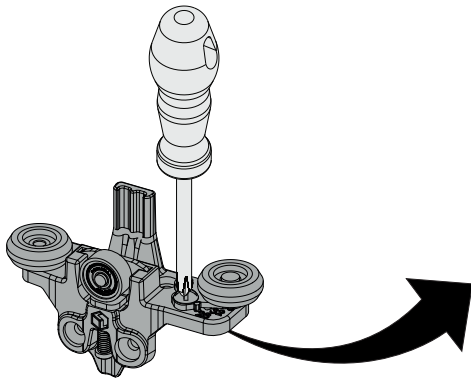

5 Instale o guia com amortecedor ou freio. | Instalar el guía con amortiguador o freno.

Obs.: faça uma furação antes da fixação dos parafusos.

Obs.: hacer una perforación antes de la fijación de los tornillos.

Amortecedor
Amortiguador

Freio
Freno

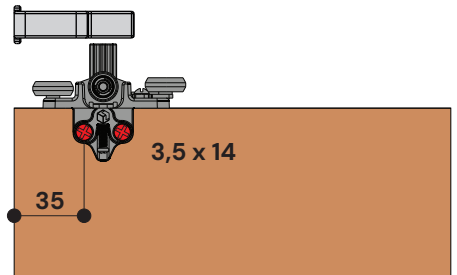
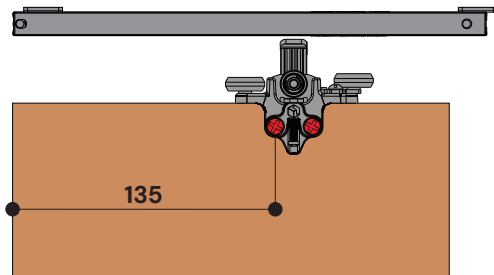

Vista superior do guia
Vista desde arriba del guía

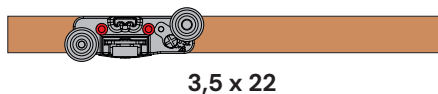

- 6** Monte a porta na caixa do móvel, encaixando primeiro a parte superior no trilho e depois encaixando os rodízios no trilho inferior. | Montar la puerta en la caja del mueble, encajando primero la parte superior en el riel y después encajando las rodas en el riel inferior.

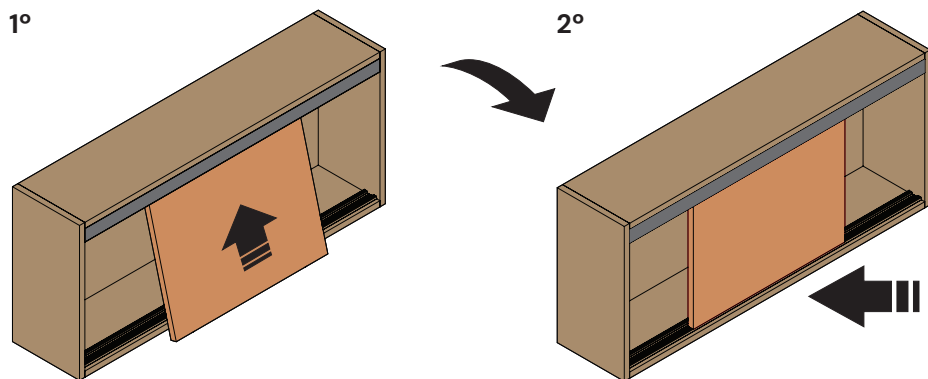

- 7** Para o ajuste do fechamento da porta, libere os dois parafusos e mova o amortecedor conforme o necessário. | Para el ajuste de cierre de la puerta, liberar los dos tornillos y desplazar el amortiguador de acuerdo con el necesidad.

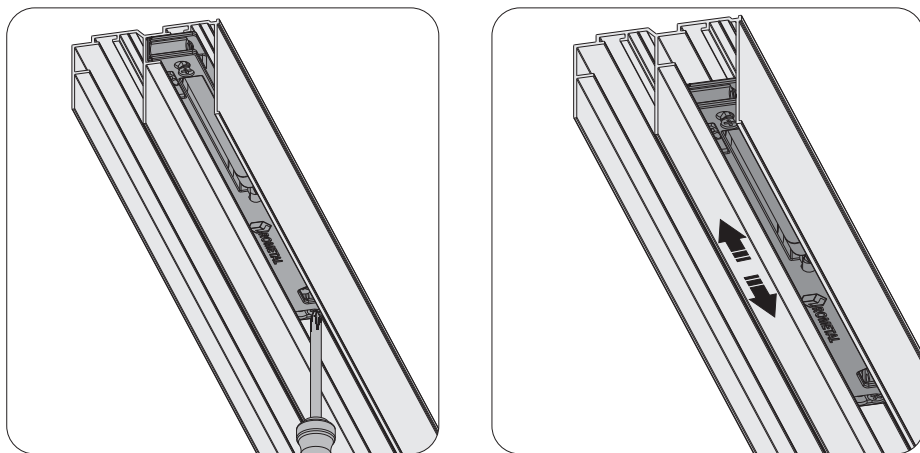

Obs.: não é necessário remover o parafuso da chapa do perfil.

Obs.: no es necesario remover el tornillo de la chapa del riel.

8

Libere a mola do carro para activar o antidescarrilamento e ajuste a altura da porta. Destrahe o resorte do carro para activar o antidescarrilado e ajuste a altura da porta.

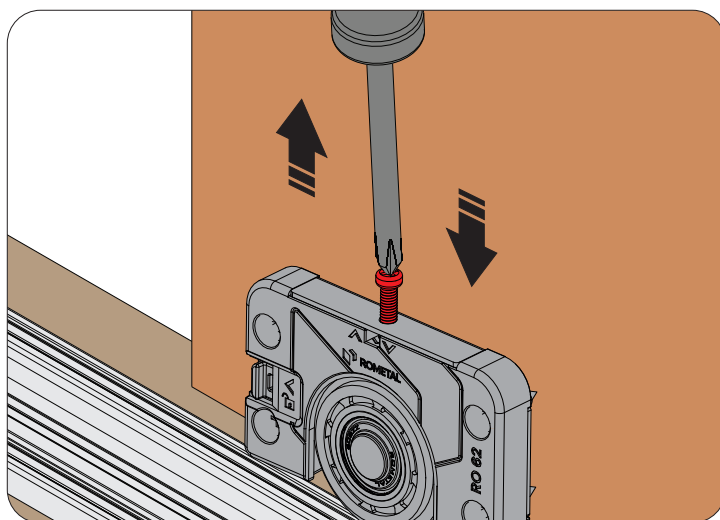
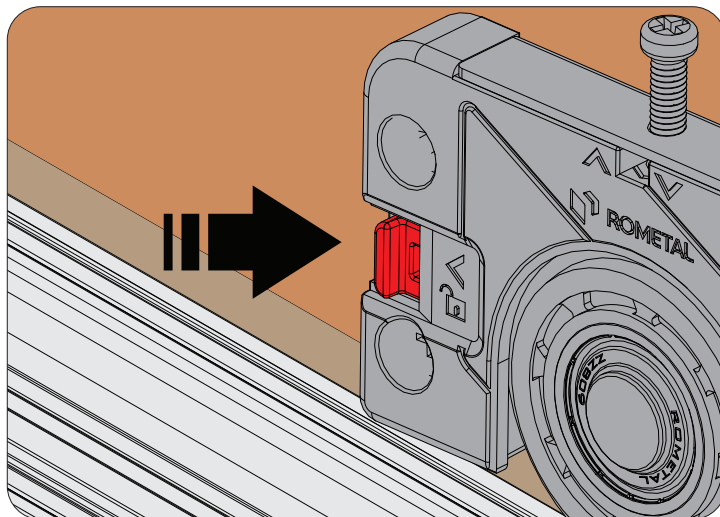

9

Ajuste o rodízio do guia para que o mesmo fique com uma pequena folga do trilho, sem encostar nele. | Ajuste la rueda del guía para que lo mismo se quede con un pequeño espacio del riel, sin tocarlo.

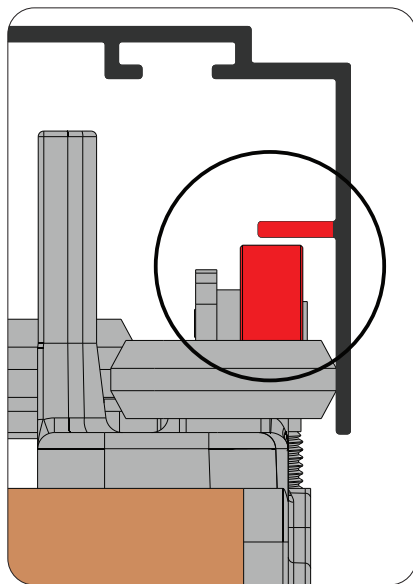
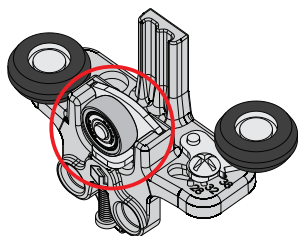
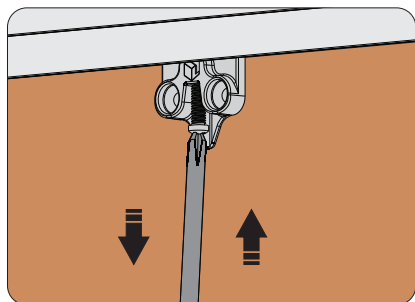

10

Composições. | Composiciones.

3 portas* / 3 puertas*

TOP

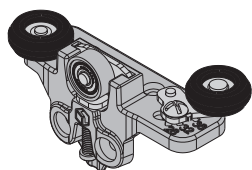
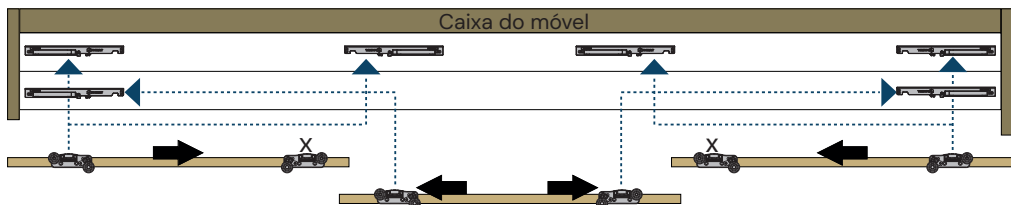

Guia sem acionador
Guía sin accionador

X: sem acionador
X: sin accionador

* Acompanha BR Close
* Acompaña BR Close

2 portas/ 2 puertas

TOP

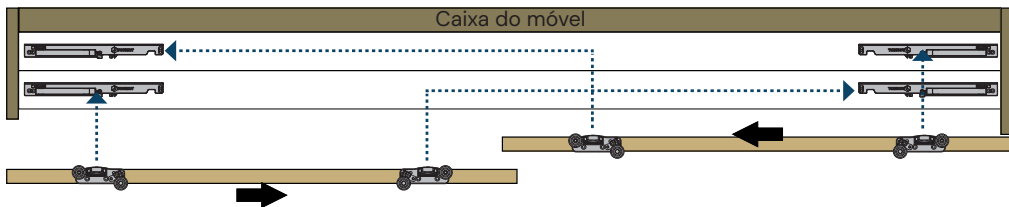

2 portas/ 2 puertas

Standard

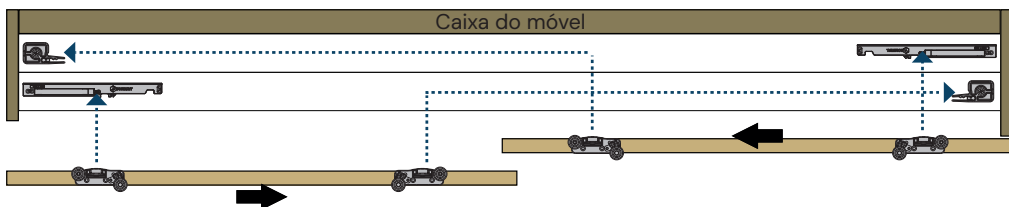

2 portas/ 2 puertas

Basic

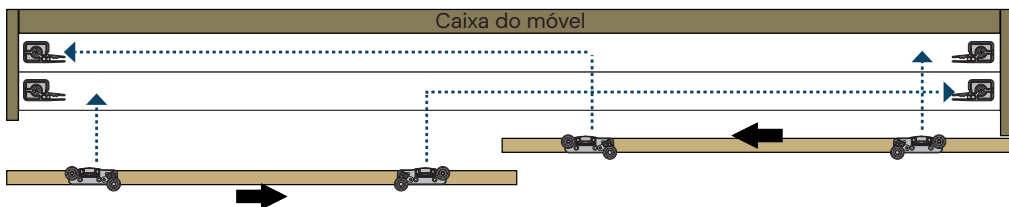

Rev.: 13 Cód.: 8513



www.rometal.com.br

Unidade Sistemas

Rodovia BR 470, km 174,5, nº 4075
Bairro Universal | Veranópolis
RS | Brasil | CEP 95330-000

Unidade Alumínio

Estrada Velha da Vacaria, nº 1339
Bairro Sapopema | Veranópolis
RS | Brasil | CEP 95330-000